

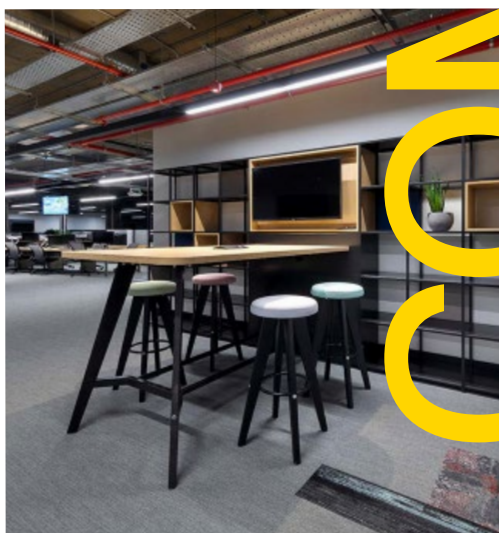

Quick Overview

SOS2



WELCOME TO OUR WORLD

Staverton has a longstanding history in office furniture design. We are recognised for bringing form, function and flexibility together without compromise. By involving our clients at every stage of the work process, we find –together– the right solution for their specific needs.

British and proud, we have a manufacturing facility in South Yorkshire and a showroom in Clerkenwell, London. With the latest BAZ processing machinery recently installed, the factory has more than 38,000 sq ft of space for manufacture and assembly and ample room for our design team to turn client requirements into fully developed designs.

Staverton's skilled team of professionals is committed to delivering the highest quality requirements: our products are designed to achieve FIRA's gold standard, the world's leading independent furniture testing centre. Our bespoke approach, innovative design and collaborative method have earned us a name as a responsible and reliable award-winning British manufacturer.

We comply with all industry regulations, including the supply of responsibly sourced wood, on-site personnel safety and conduct, quality control, and adherence to management standards such as ISO 9001, ISO 14001, BSI Membership, Safe Contractor Certificate, FIRA Gold Certificate, FISP Membership and FSC Certificate.



012



The mark of responsible forestry



POSITIVE CHANGE



We need to be the change we want to see. Leading by example while learning from others is the best way to drive change.

Business as usual is no longer enough. Nor is merely complying with regulations. We must do more than is expected of us. We need to improve each day. We need to understand our whole impact on the world. And we need to work together to ensure that we learn from each other and drive change.

There is an onus on us not just as manufacturers and designers of products but as individuals. Sustainability can be designed into systems and products, but the real change we need to see is in our attitudes and behaviours. We are all in this together and we all have a role to play.

[Join Us](#)

Respect for the environment is in Staverton's DNA. We care for our setting by creating sustainable, environmentally friendly products.



Find the Height That Suits You Best

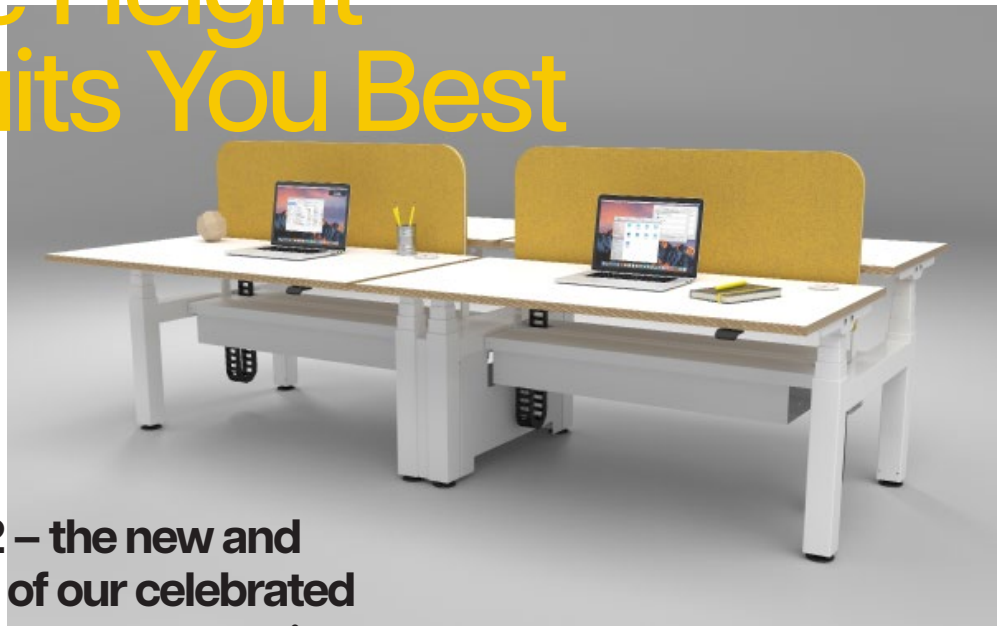

Introducing SOS2 – the new and improved version of our celebrated SOS range of sit-stand workstations we first launched in 2014.

Product Main Features

Improved and scalable cable management including.

Bulk-Capacity cable riser to hide cable ingress.

Intermediate leg to reduce costs on linked bench runs.

Hot-swappable actuators to enable easy conversion between fixed and height adjustable positions.

Mobile option available on braked castors for agile working.

Retrofittable linking allows for easy reconfiguration of desk clusters.

Sliding top option for easy cable access at rear of workstation.

18mm fixed top option facilitates the use of a wider variety of finishes.

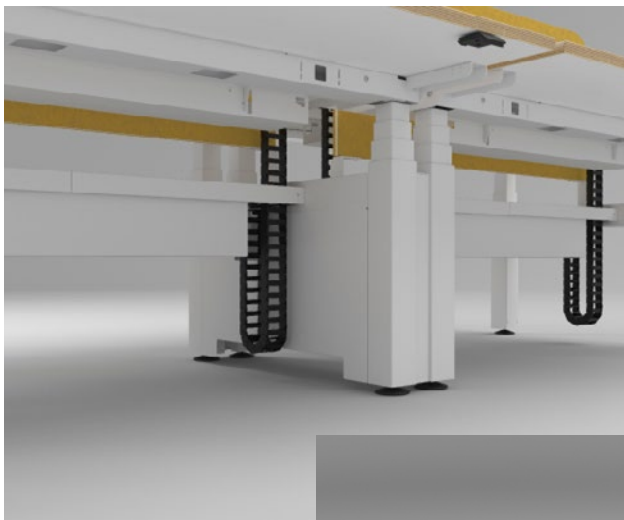

Intermediate leg offering to reduce cost on long linked runs.



Hot-swappable actuator columns, which means it can be fixed height and evolve to sit-stand over time.

Standard and High Capacity Lower Cable Management

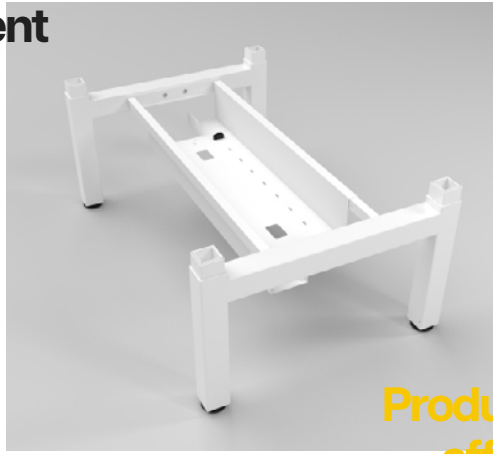
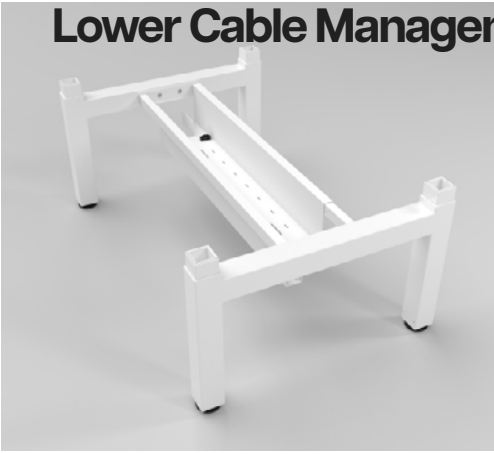

The spacious lower cable management tray comes in two sizes: standard (31,365cm³) and high-capacity (53,550cm³).

Productive, healthy and efficient workspaces encourage employees to move more.

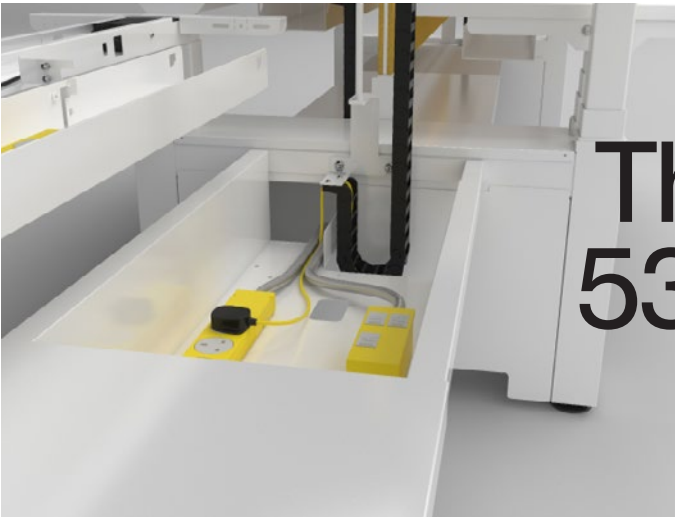

The UK's Largest 53,500cm³ Cable Management Provision

The high-capacity tray is 70% bigger than the standard one – leaving plenty of room for power bars, PDUs, and data modules.

Bulk-Capacity Cable Riser

The leg frame cladding creates an 80 or 190mm void that allows a great spatial capacity. The panels are straightforward to attach or remove using reliable magnetic clips.

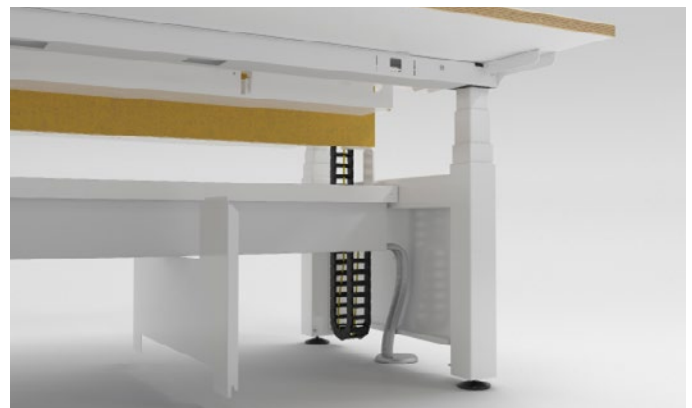
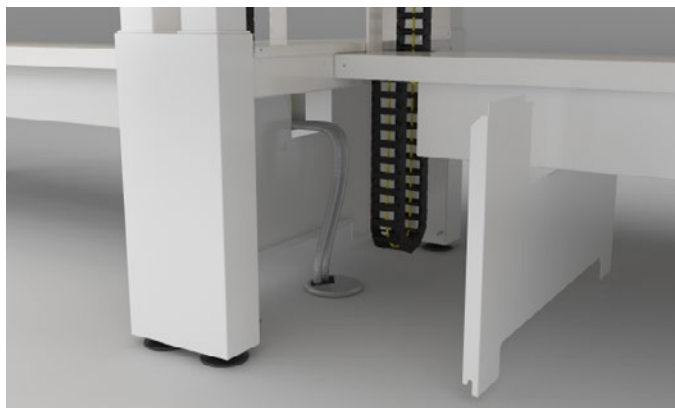

Typical Bench Configuration



**Height Adjustable Back-To-Back
Bench**

Typical Desk and Corner Desk Configurations



Height Adjustable Desk



**Height Adjustable Corner
Desk**

Bench Assembly

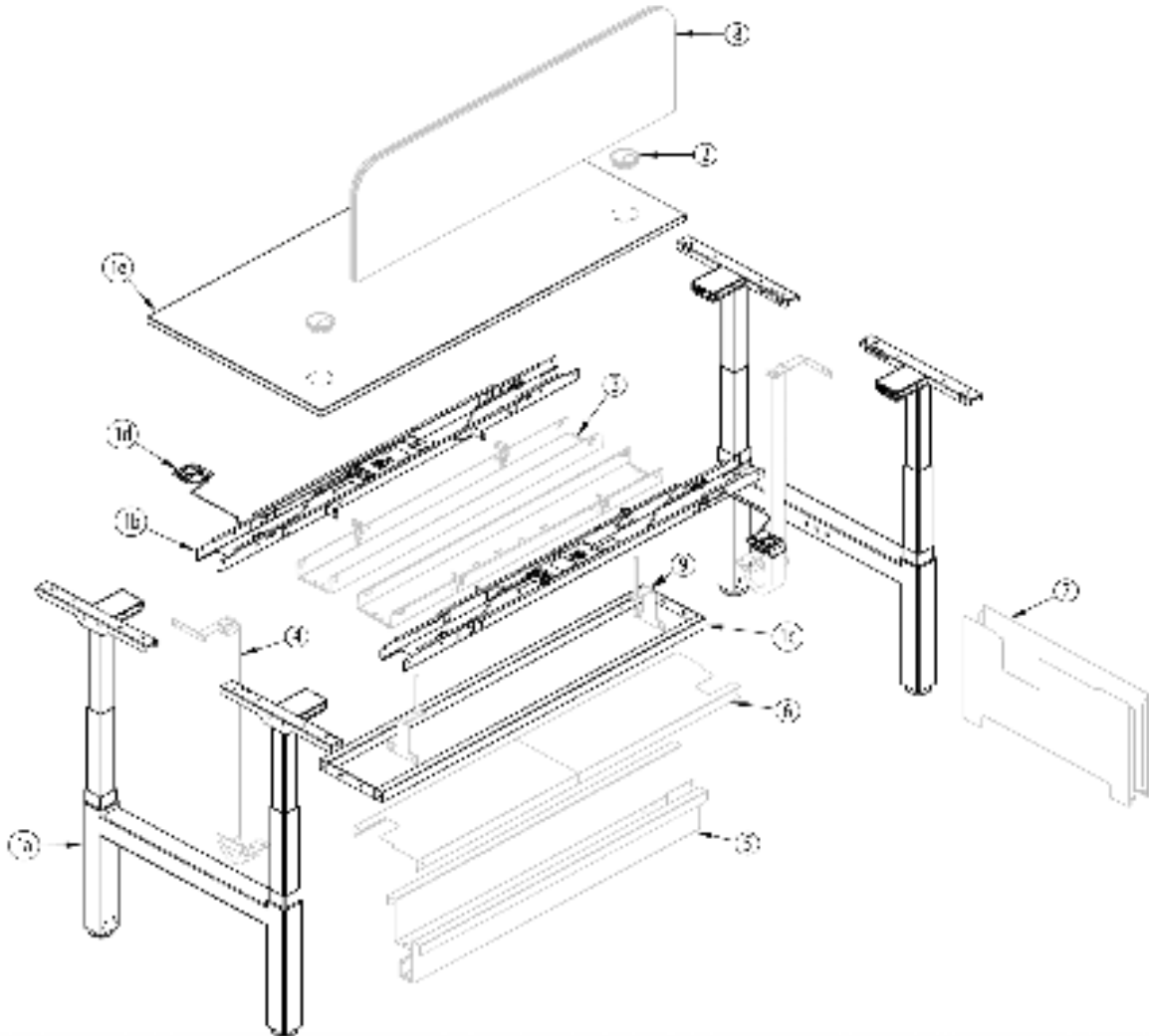

Bench Module, consisting of:

- 1a: 2x Bench end Leg Frames
- 1b: 2x Structural Upper Beams
- 1c: 1x Lower Beam
- 1d: 2x Electric Power/Control Kits
- 1e: 2x Top Panels and Above

Accessories to be ordered separately:

- 2: 4x Round Cable Outlets 'RW1PCG'
- 3: 2x Upper Cable Management Trays 'LW1UCT' or 'YW1ICT'
- 4: 2x Bench Umbilical Cable Risers 'YW1BCR'
- 5: 1x Bench Cable Tray 'YW1ABT' or 'YW1BBT'
- 6: 1x Bench Cable Tray Cover (2-part) 'YW2ABC' or 'YW2BBC'
- 7: 1x Bench End Leg Cladding Panels 'YW1LCE'
- 8: 1x Bench Screen 'YTBUNS' or 'YTBUNT'
- 9: 1x Bench Screen Brackets (pair) 'YC2BSS'

Bench Runs

Bench runs can be created by either linking individual bench modules together, or adding bench extension modules.

Linked Benches

Two-person bench modules are linked together, creating the mandatory 30mm safety gap between the bench worksurfaces.

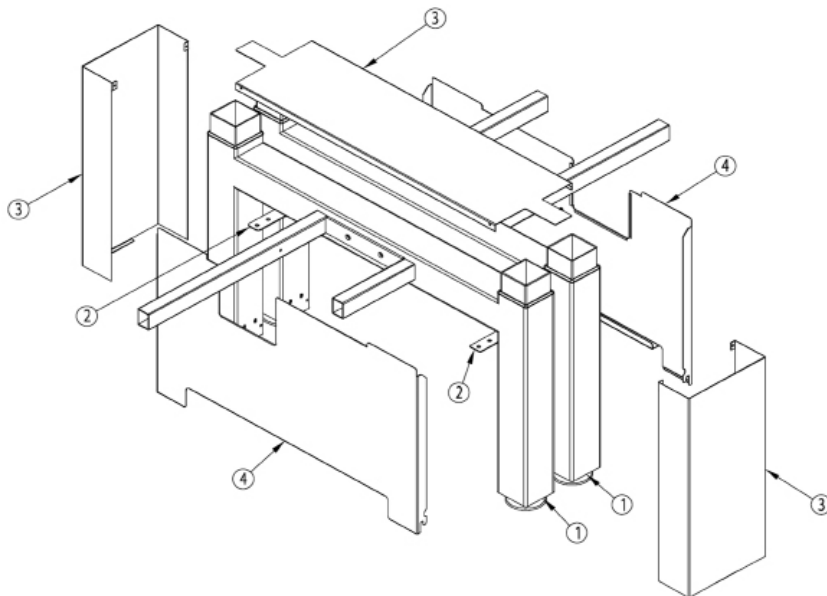

1: Bench end Leg Frames (part of bench assembly)

2: Bench Side-to-Side Linking Brackets (pair) 'YC2BLB'

Or

3: Bench Side-to-side Cladding Panels 'YC1BLC' (includes linking brackets).

Optional

4: Bench Intermediate Leg Cladding Panels 'YW1LCI'

Bench Extension

Bench Extensions feature an Intermediate Leg Frame that is shared with the adjoining bench, and creates the mandatory 30mm safety gap between the bench worksurfaces.

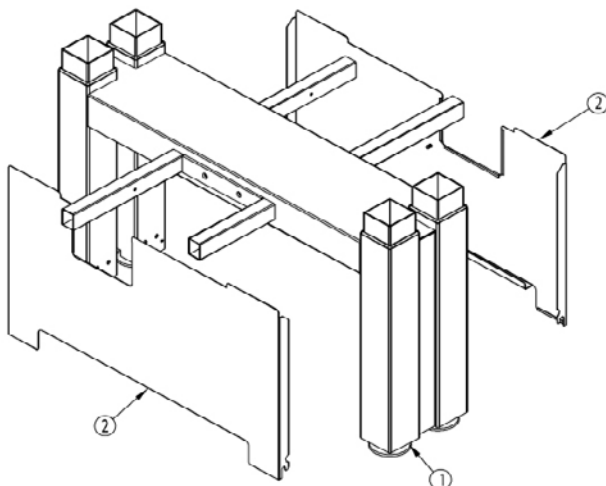

1: Bench Intermediate Leg Frame (part of bench extension assembly)

Optional

2: Bench Intermediate Leg Cladding Panels 'YW1LCI'

Desk Assembly

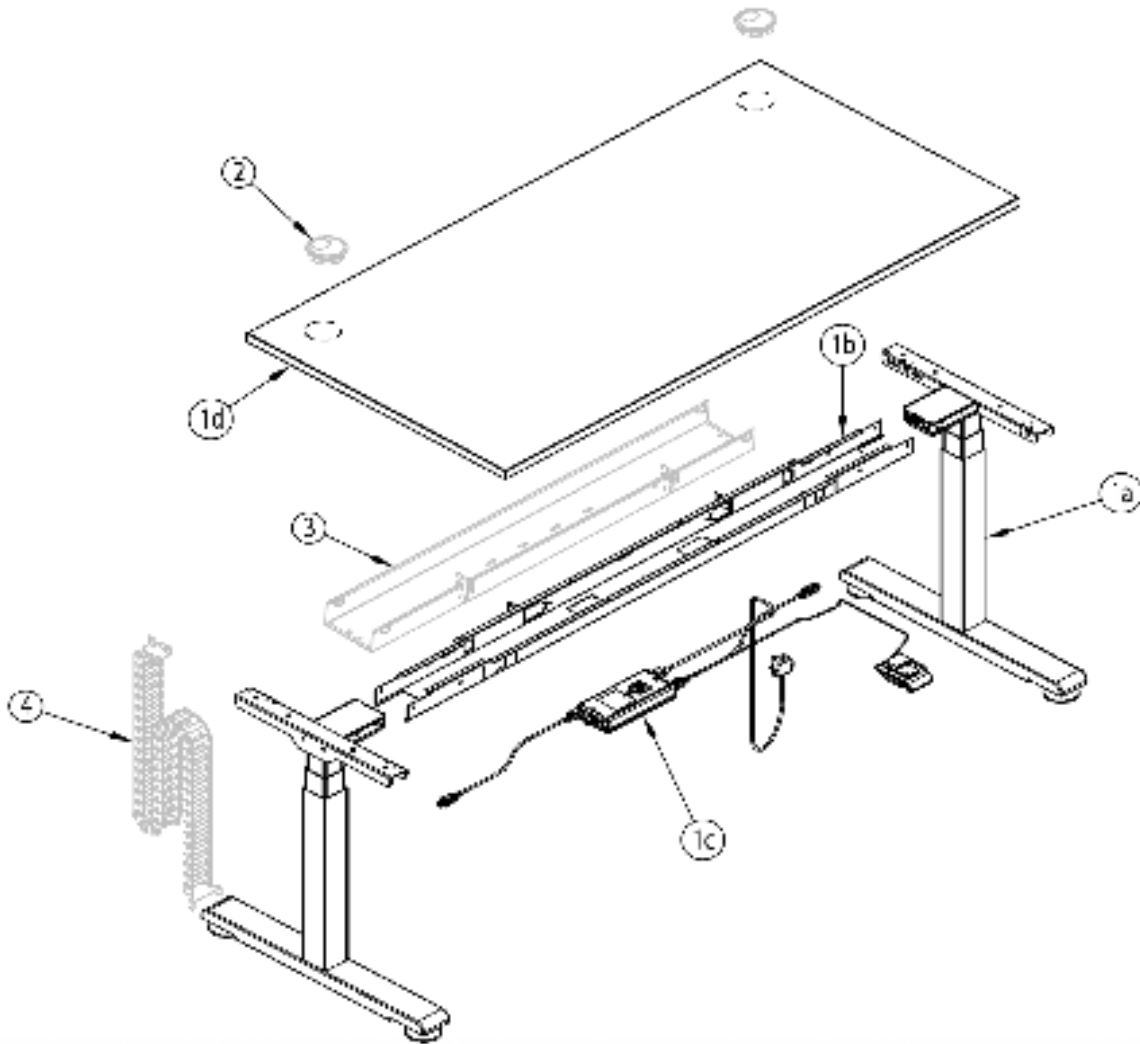
**Desk Module, consisting of:**

- 1a: 2x Desk End Leg Frames
- 1b: 1x Structural Upper Beam
- 1c: 1x Electric Power/Control Kit
- 1d: 1x Top Panel

Accessories to be ordered separately:

- 2: 2x Round Cable Outlets 'RW1PCG'
- 3: 1x Upper Cable Management Tray 'LW1UCT' or 'YW1ICT'
- 4: 1x Desk Umbilical Cable Riser 'YW1DCR'

Corner Desk Assembly

SOS2

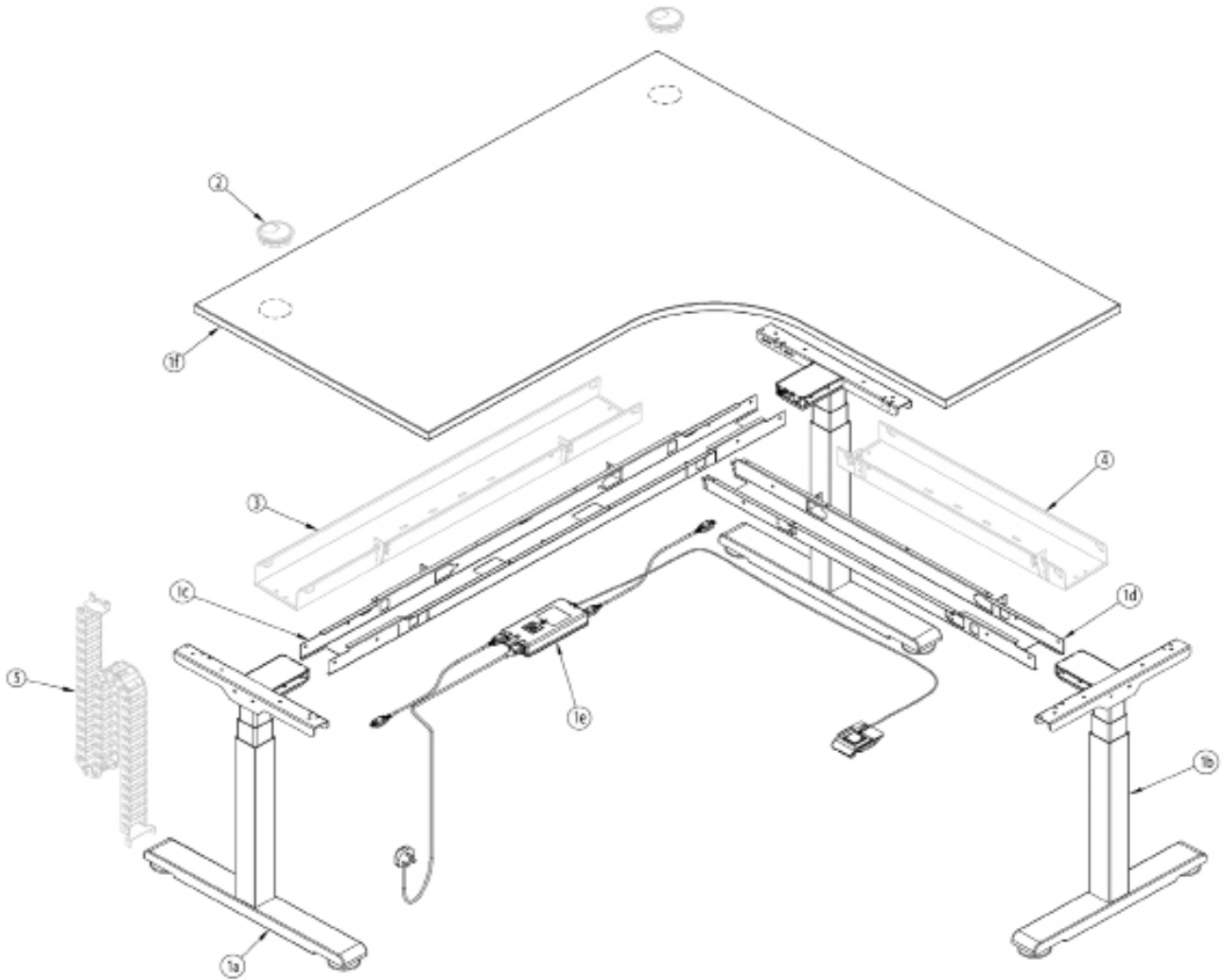

Desk Module, consisting of:

- 1a: 2x Desk End Leg Frames (fixed top)
- 1b: 1x Return Desk End Leg Frame (fixed top)
- 1c: 1x Structural Upper Beam
- 1d: 1x Return Beam
- 1e: 1x Electric Corner Desk Power/Control Kit
- 1f: 1x Core Top Panel

Accessories to be ordered separately:

- 2: 2x Round Cable Outlets 'RW1PCG'
- 3: 1x Upper Cable Management Tray 'LW1UCT'
- 4: 1x Upper Cable Management Tray 'LW1UCT' Cable Trays can only be specified on the return side of the desks 1585w² and above
- 5: 1x Desk Umbilical Cable Riser 'YW1DCR'

Finishes

Standard Worksurfaces and ABS Edge Finishes (25mm Thick Melamine)

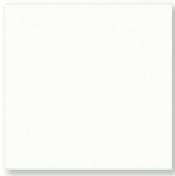

Traffic White
W1000



Sand Birch
H1732



Oak
D1929

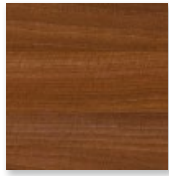

Walnut
H3704

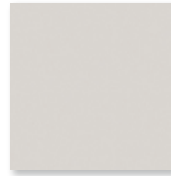

Light Grey
U708



Dust Grey
U732



Anthracite
U164

Special 36x Plain Colours Available¹ on 18mm Worksurfaces E.g:

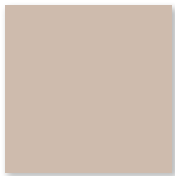

Cappuccino
U3053



Coral
U7110



Rose
U325



Sand Yellow
U125



Sage Green
U638



Tyrolean Blue
U504



Turquoise
U159

Contrast Edging



Black
U999



2D Ply
'S'

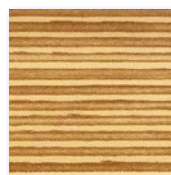

3D Ply²
'M'

Frame

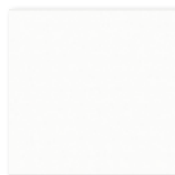

Satin White
'K'

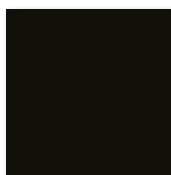

Satin Black
'P'

Notes

¹ Special Worksurface Finish, choose more colour options from the Swiss Krono One World Collection [here](#).

² Premium Edge Finish - 3D Ply 'M'

Fabric Band Information

Fabric Band B



Camira Lucia

Fabric Band C



Camira Blazer Lite

Fabric Band E



Camira Blazer



Camira Synergy

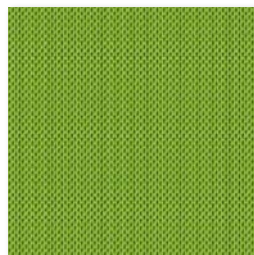

Camira Nexus

Notes

All fabrics are foam backed with 2mm or 3mm foam backing (as appropriate) to achieve the best possible finish and feel.

Dimension Guide

Electric Height Adjustable Bench

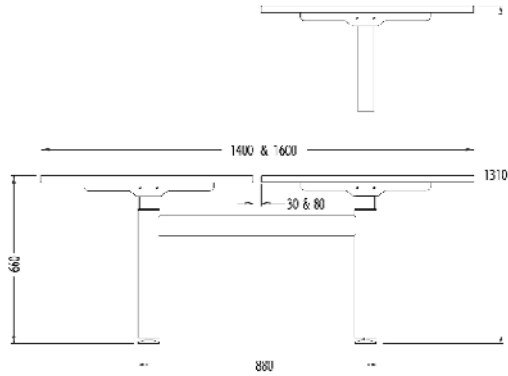

Bench Module 1400mm Deep

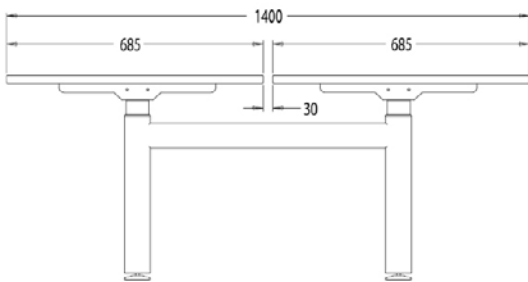

Cable Gap 30mm - Ref: 'G'

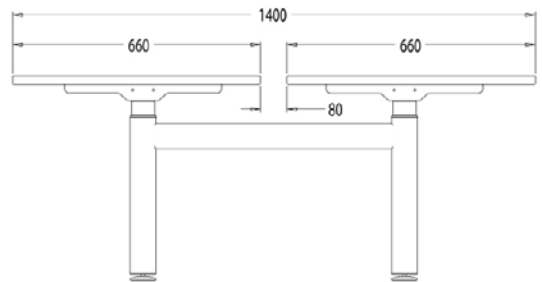

Screen Gap 80mm - Ref: 'P'

Bench Module 1600mm Deep

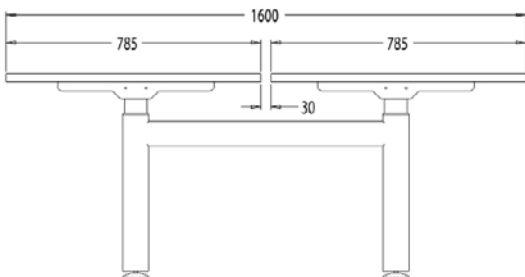

Cable Gap 30mm - Ref: 'G'

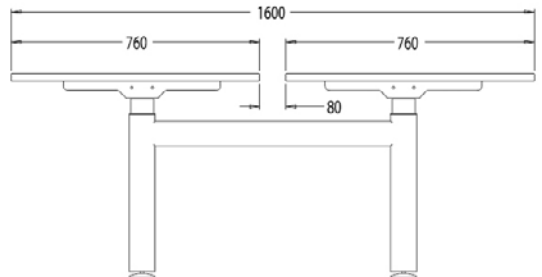

Screen Gap 80mm - Ref: 'P'

Dimension Guide

Desk with Rounded Feet and Glides

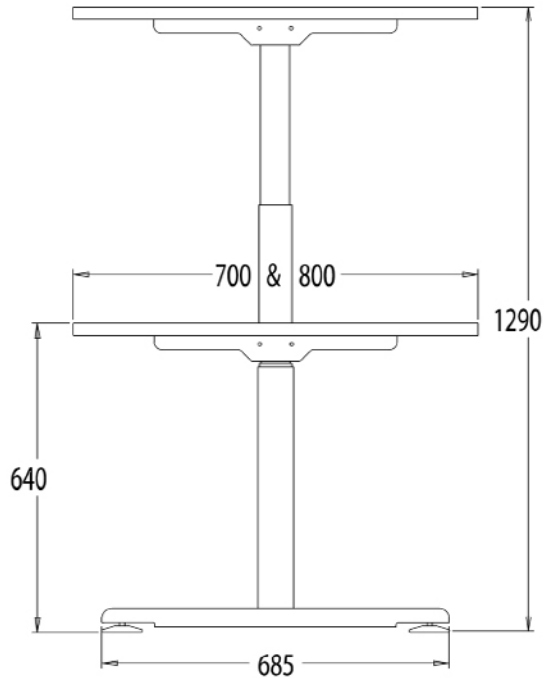

Desk with Rounded Feet and Castors

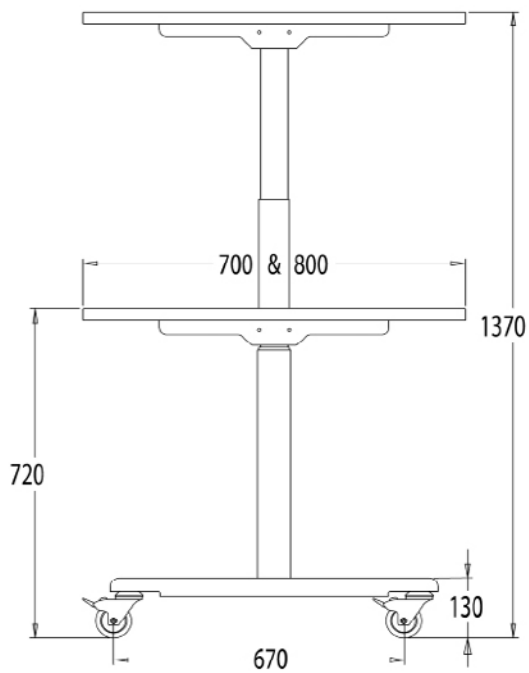

Dimension Guide

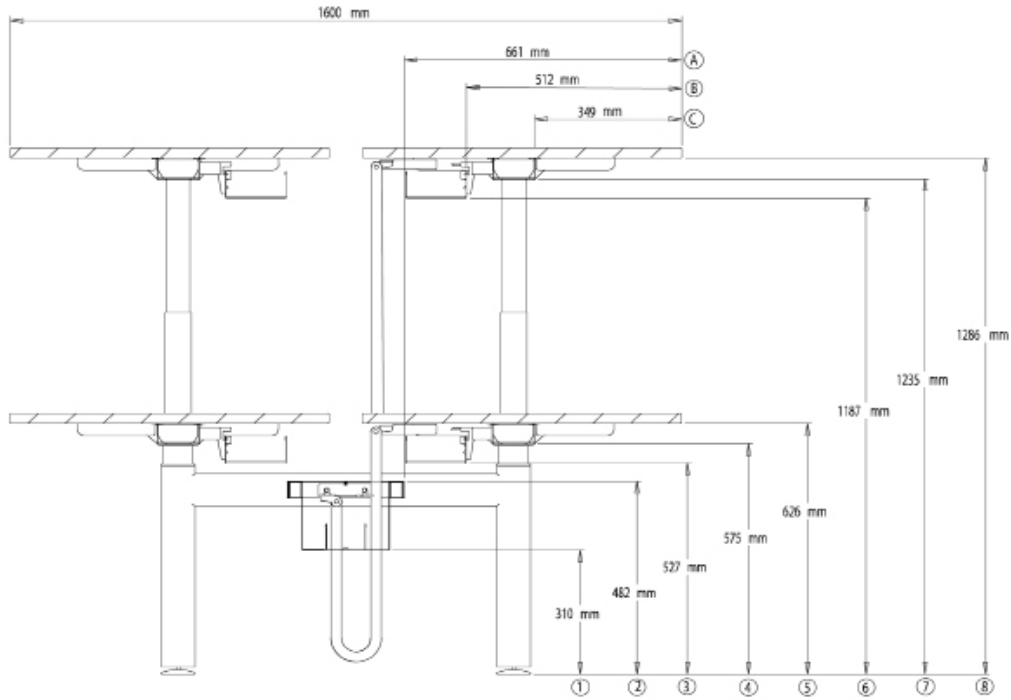

Key

- A - Front edge of worksurface to lower cable tray
- B - Front edge of worksurface to upper cable tray
- C - Front edge of worksurface to upper beam

- 1 - Floor to bottom of lower cable tray
- 2 - Floor to top of lower cable tray

- 3 - Floor to upper cable tray (Lowest)
- 4 - Floor to upper beam (Lowest)
- 5 - Floor to underside of worksurface (Lowest)
- 6 - Floor to upper cable tray (Highest)
- 7 - Floor to upper beam (Highest)
- 8 - Floor to underside of worksurface (Highest)

Bench Cable Tray Access Capacity

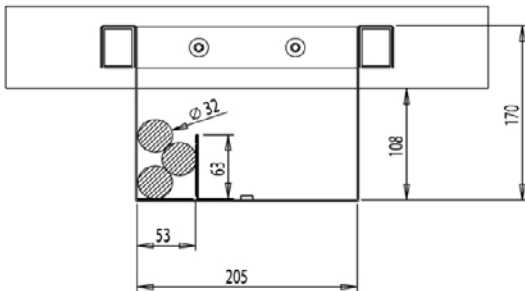

Standard Cable Tray

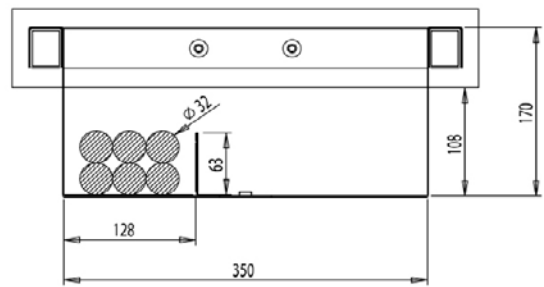

High-Capacity Cable Tray

Notes

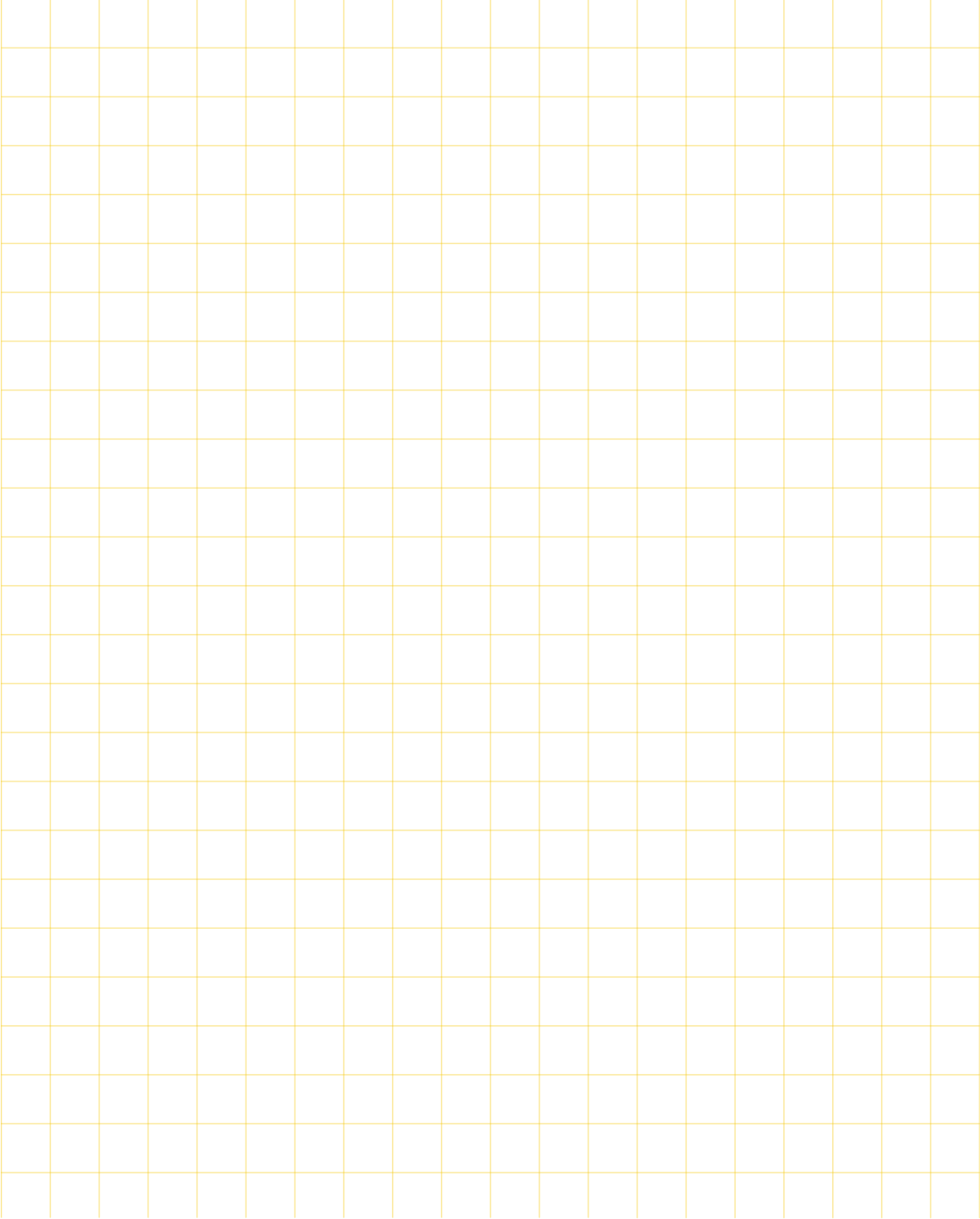

Showroom

Conveniently located in London, our newly refurbished Clerkenwell showroom exhibits Staverton's wide range of products. Come and visit us to see our offering for yourself.

[17-18 Hayward's Place](#)
[London, EC1R 0EQ](#)

Stay in Touch

To find out more or book an appointment, please contact us.

+44 (0)20 3794 1200
info@staverton.co.uk
staverton.co.uk



Staverton reserves the right to alter the prices and specifications without notice.



012



The mark of responsible forestry

